

LOOP OVAL UNDER-COUNTER BASINS with Tap Shelf

Product Image

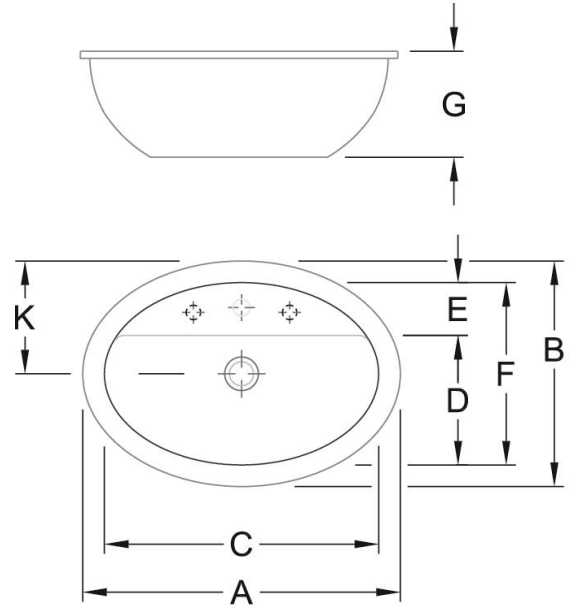

Technical Specification



Note:
- Tapware not included

	A	B	C	D	E	F	G	K
5161 60	660	470	560	270	100	370	215	235
5161 50	570	400	485	215	100	315	200	200

Installation Notes:

- No cut-outs should be attempted in bench top without having the actual Basin/s that are going to be installed.
- Only Silicon based adhesives should be used, not epoxy resins.
- Overflow hole should be positioned closest to the front of the cabinet.

Code/Description

Loop Oval Under-Counter Basins with Tap Shelf
OD 570x400mm / ID 485x315mm

- 51615001** 1 Taphole
- 51615001SDL** 1 Taphole with Liquid Soap Dispenser on Left-Hand Side
- 51615001SDR** 1 Taphole with Liquid Soap Dispenser on Right-Hand Side

Loop Oval Under-Counter Basins with Tap Shelf
OD 660x470mm / ID 560x370mm

- 51616001** 1 Taphole

Additional Information

- 5 Year Warranty *Conditions Apply
- Recommended Waste 94240

